

YEM PAKETLEME MAKİNASI

Feed Packing Machine

IGM MACHINE

TEK- ÇİFT TERAZİLİ
Single-Double Weigher

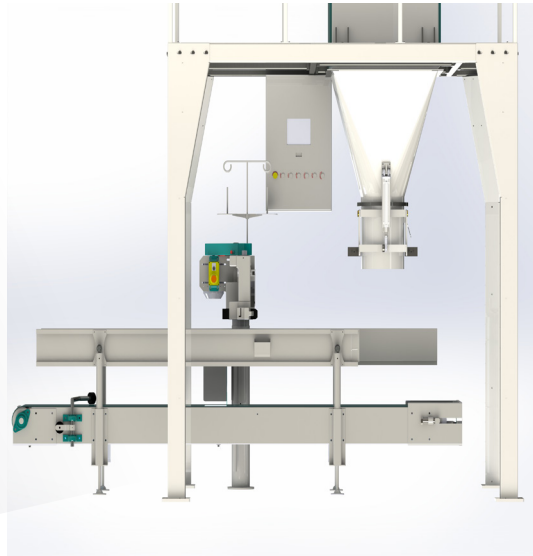
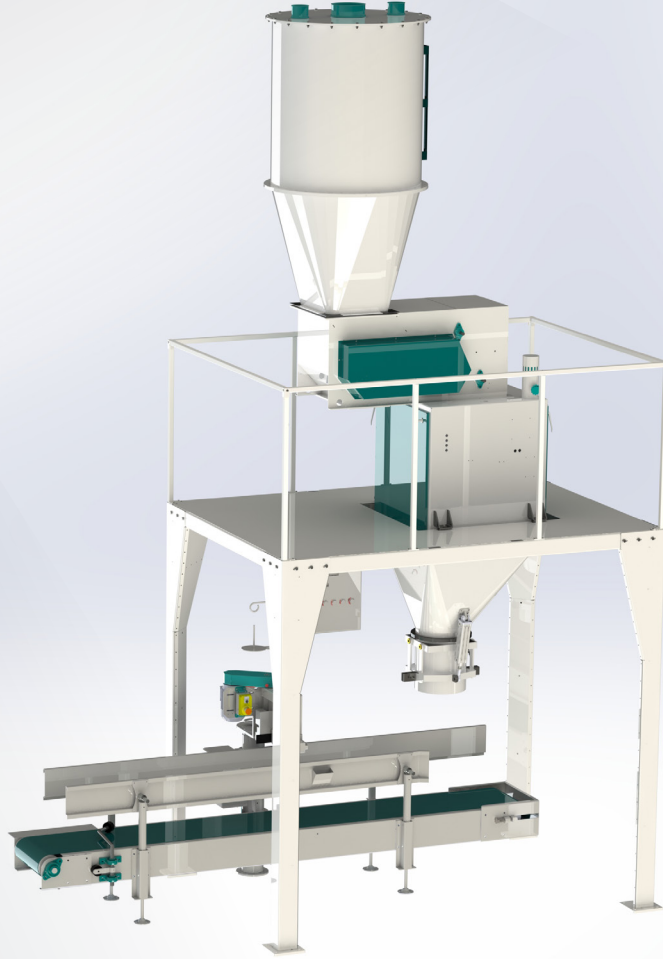

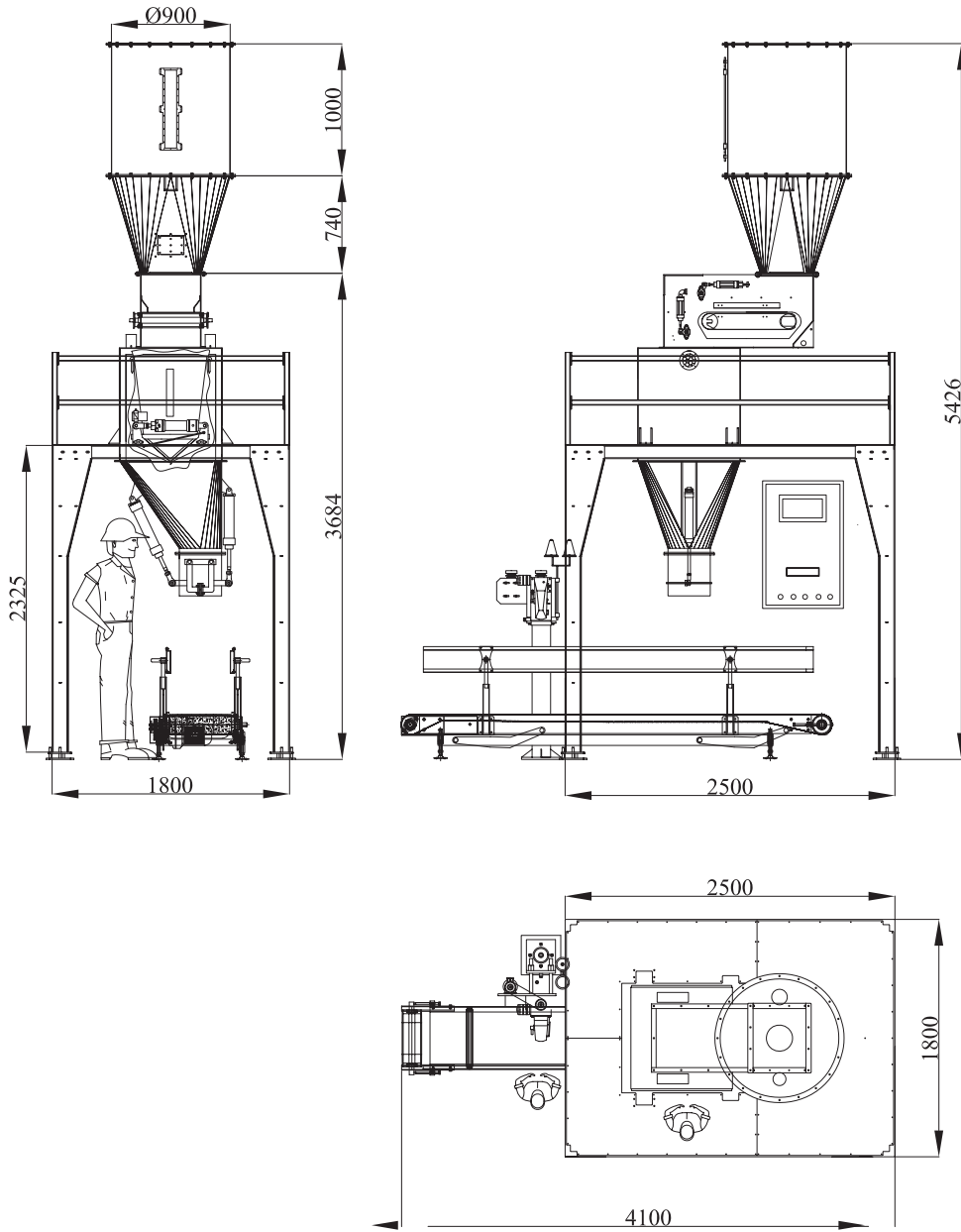

TARTIM KAPASİTESİ WEIGHING CAPACITY	ELEKTRİK TÜKETİMİ ELECTRICITY CONSUMPTION	ELEKTRİK ÇIKIŞI ELECTRICAL OUTPUT	HAVA BASINCI AIR PRESSURE	BESLEME BUNKERİ HACMİ FEED VOLUME
TEK TARTIM : 6-7 tor/dk SINGLE WEIGHING:6-7 bag/min.	3.5 kw /h	400 V/50-60 hz	6-8 bar	0.9 (m ³)
ÇİFT TARTIM : 11-13 tor/dk DOUBLE WEIGHING:11-13 bag/min.	5 kw/h		6-8 bar	1.5 (m ³)

TR

- Çuval sıkıştırma ağızı,
- Beslenme helezonu,
- Taşıma platformu
- Dikiş bantı; hidrolik sistem yükseklik ayarı,
- Dikiş makinası ayağı; manuel yükseklik ayarı
- Elektronik sistem dolum kontrolü
- Kullanılan silindirler FESTO markalıdır.

ENG

- Bag holding kit
- Feeding screw
- Machine frame
- Sewing belt; hydrolically height-adjustable
- Sewing machine's leg is manually height-adjustable
- Electronical controller
- Cylinders are FESTO