

# UN PAKETLEME MAKİNASI

## Flour Packing Machine

  
IGM MACHINE

**5-10 kg TEK - ÇİFT TARTIMLI**  
5-10 kg Single - Double Weigher

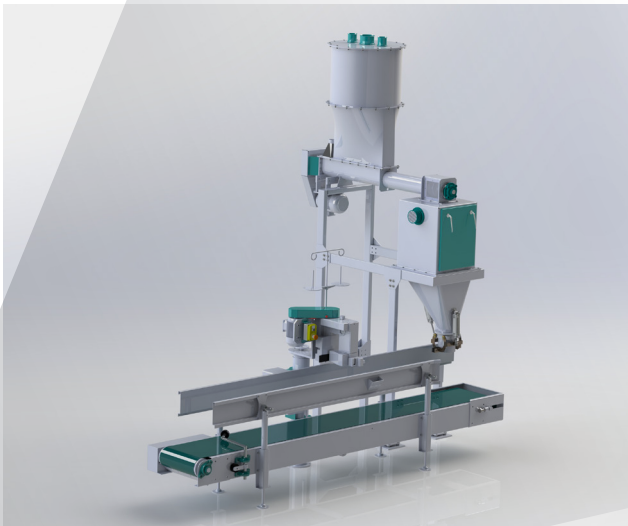
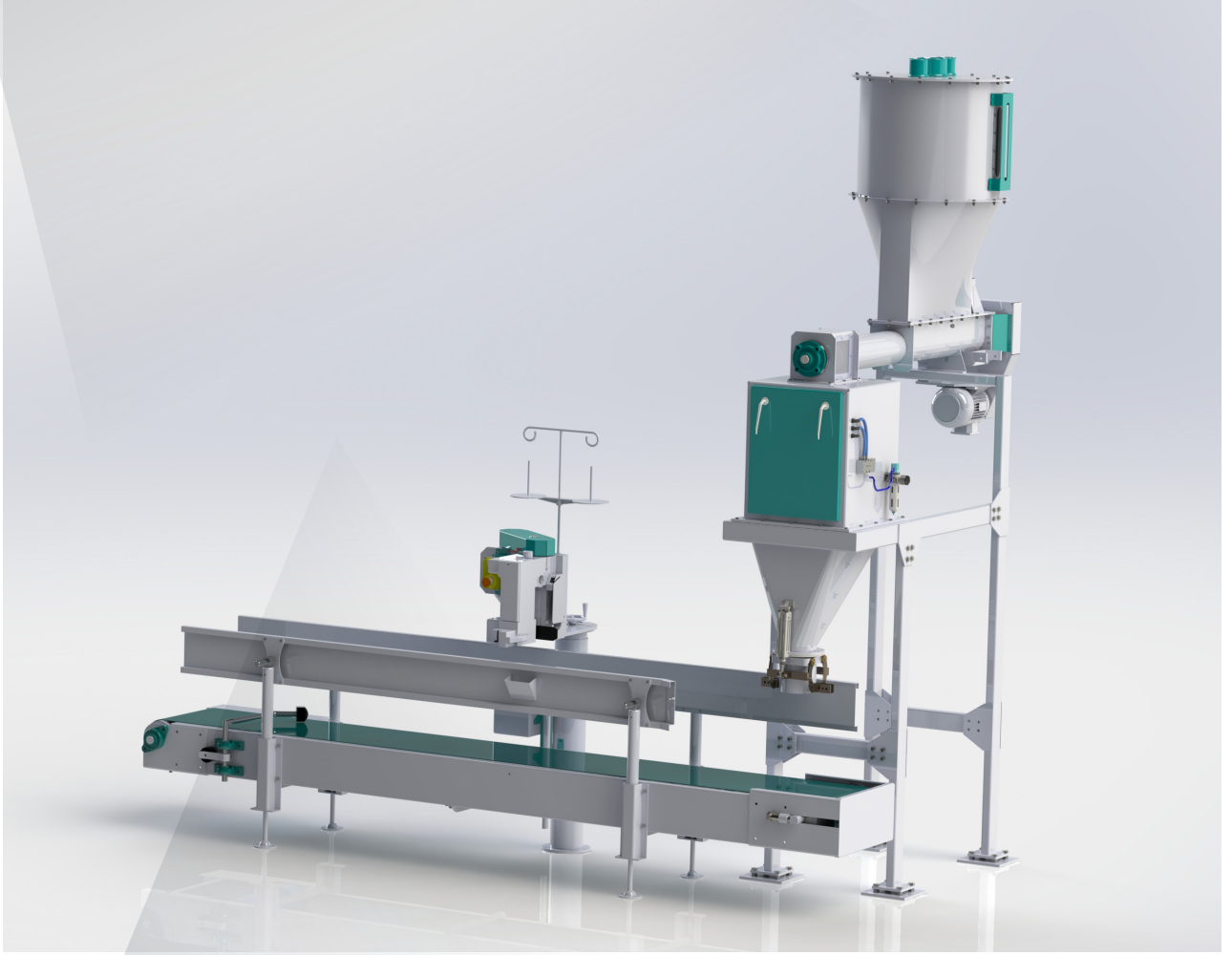

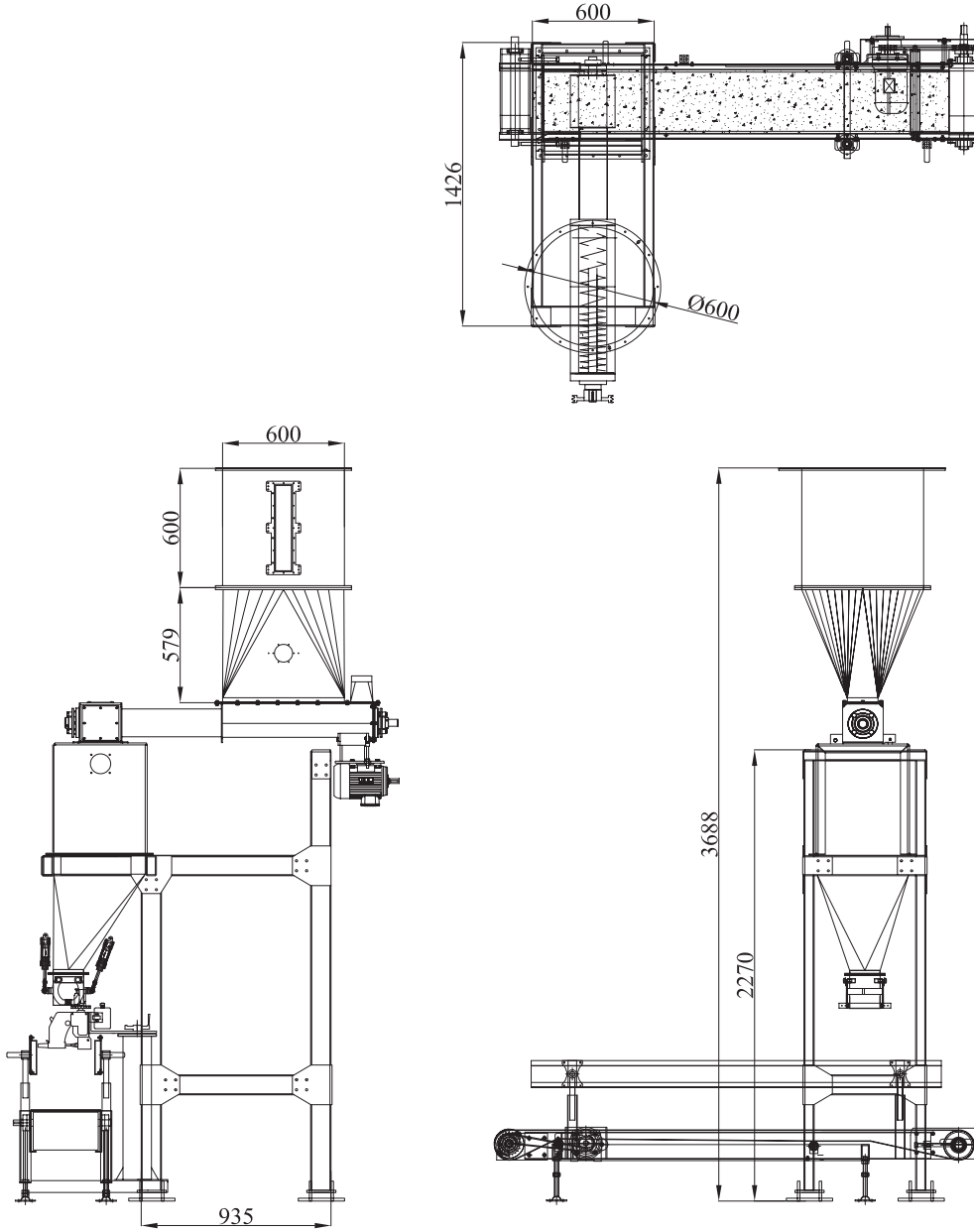

TARTIM KAPASİTESİ WEIGHING CAPACITY	ELEKTRİK TÜKETİMİ ELECTRICITY CONSUMPTION	ELEKTRİK ÇIKIŞI ELECTRICAL OUTPUT	HAVA TÜKETİMİ AIR CONSUMPTION	BESLEME BUNKERİ HACMİ FEED VOLUME
TEK TARTIM : 5-7 tor/dk SİNGLE WEIGHING:6-8 bag/min.	3.2 (kw)	400 V/50-60 hz	6-8 bar	0.3 (m <sup>3</sup> )
ÇİFT TARTIM :10-12 tor/dk DOUBLE WEIGHING:10-12 bag/min.	4.5 (kw)			

### TR

- Çuval sıkıştırma ağızı,
- Beslenme helezonu,
- Taşıma platformu
- Dikiş bantı; manuel yükseklik ayarı,
- Dikiş makinası ayağı; manuel yükseklik ayarı
- Elektronik sistem dolum kontrolü
- Kullanılan silindirlere FESTO markalıdır.

### ENG

- Bag holding kit
- Feeding screw
- Machine frame
- Sewing belt; height-adjustable
- Sewing machine's leg is manually height-adjustable
- Electronical controller
- Cylinders are FESTO