

RANDIMAN GÖSTERGE SİSTEMİ

Extraction Rate Monitoring System

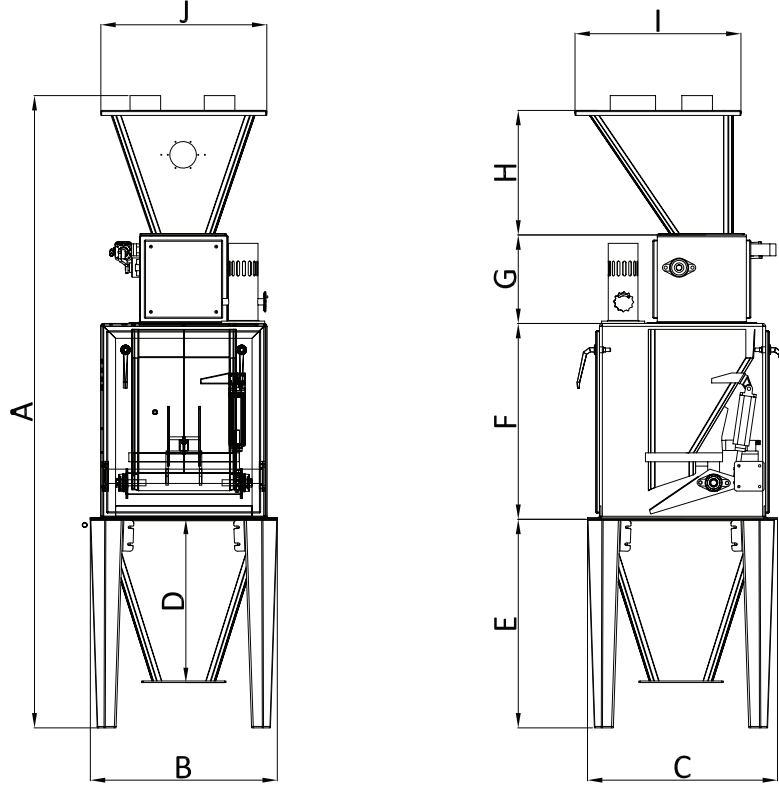



MODEL	A	B	C	D	E	F	G	H	I	K	KAPASİTE UN / FLOUR t/h	KAPASİTE BUĞDAY / WHEAT t/h	KAPASİTE KEPEK / BRAN t/h
DMRK-350	2131	630	640	550	703	660	298	420	559	559	6	8	3
DMRK-420	2221	710	715	550	695	758	298	420	559	559	10	12	5
DMRK-550	2565	850	850	765	900	897	298	420	559	559	17	25	8
DMRK-800	3306	1110	1110	700	955	1130	471	750	1000	1000	33	50	17

MODEL	ELEKTRİK TÜKETİMİ ELECTRICITY CONSUMPTION	ELEKTRİK ÇIKIŞI ELECTRICAL OUTPUT	HAVA BASINÇI AIR PRESSURE	BESLEME BUNKERİ HACMİ FEED VOLUME	DÖKÜŞ BUNKERİ HACMİ DUCT CONTAINER VOLUME
DMRK-350	1.5 kw/h	400V / 50-60 Hz	6-8 bar	0.06 m ³	0.07 m ³
DMRK-420	1.5 kw/h			0.06 m ³	0.08 m ³
DMRK-550	2 kw/h			0.06 m ³	0.11 m ³
DMRK-800	3 kw/h			0.4 m ³	0.3 m ³

TR

- PLC sistemli
- Tek ve ya network halinde çalışma
- Buğday kantarında kapasite ayarlama imkanı
- Geçmiş günlere ait verileri raporlama
- Merkezden bağımsız çalışabilme
- Kullanılan silindripler FESTO markalıdır.

ENG

- PLC system
- Able to work single or in network
- Capacity setting in wheat scale
- Reports the past dates
- Ability to work independently from center
- Cylinders are FESTO